



Real Quality

Real Value



MAC CHAIN CO. LTD.

Established in 1979. A family owned and operated business.



WELDED STEEL MILL CHAIN - OFFSET SIDEBAR



These heavy duty chains are recommended for most conveying and elevating applications where a high strength steel rollerless chain is required. A complete line of attachments and optional heat treatment make them easily adaptable to a wide variety of installations.

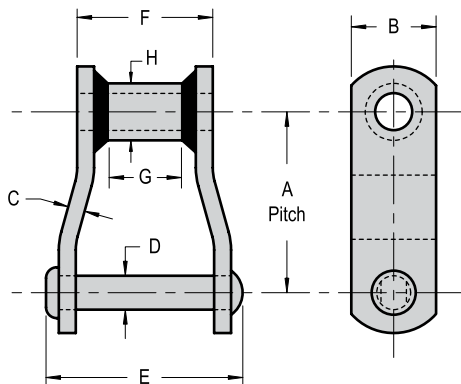

- All pins are through-hardened
- 1" & larger pins are further induction-hardened

All dimensions shown in inches unless noted otherwise

Chain Number	Average Pitch	Ultimate Strength (Pounds)	WH* Ultimate Strength (Pounds)	Sidebar Height	Sidebar Thickness	Rivet Diameter	Approx. Overall Width	Length of Bearing	Max. Sprocket Thickness	Barrel O.D.	Links per Foot	Average Weight per Foot (Pounds)
	A			B	C	D	E	F	G	H		
WS78**	2.609	29,800	34,000	1 1/4	1/4	1/2	2 7/16	1 5/8	3/4	0.84	4.6	3.9
WR78	2.609	29,800	34,000	1 1/4	1/4	1/2	3	2	1	0.84	4.6	4.1
WR78XHD	2.640	32,700	38,500	1 1/4	3/8	9/16	3 9/32	2	1	1.05	4.5	6.3
WR78-4	4.000	29,800	34,000	1 1/4	1/4	1/2	3	2	1	0.84	3	3.4
WR82	3.075	32,750	37,000	1 1/4	1/4	9/16	3 5/16	2 1/4	1 3/8	1.05	3.9	4.7
WR82XHD	3.075	50,400	57,000	1 1/4	3/8	3/4	3 13/16	2 3/8	1 1/8	1.25	3.9	8.4
WR124	4.000	50,400	57,000	1 1/2	3/8	3/4	4 1/4	2 13/16	1 1/2	1.25	3	8
WR124XHD	4.050	85,500	122,000	1 1/2	1/2	1	4 7/8	3	1 1/2	1.66	3	14.5
WR111	4.760	50,400	60,000	1 3/4	3/8	3/4	4 13/16	3 3/8	2 1/4	1.25	2.5	8.6
WR106	6.000	50,400	60,000	1 1/2	3/8	3/4	4 1/4	2 13/16	1 1/2	1.25	2	6.5
WR106XHD	6.050	85,500	122,000	1 1/2	1/2	1	4 7/8	3	1 1/2	1.66	2	11.5
WR132	6.000	85,500	122,000	2	1/2	1	6 1/4	4 7/16	3 1/8	1.66	2	13.5
WR132XHD	6.050	118,500	142,000	2	5/8	1	6 3/4	4 11/16	3 1/8	1.66	2	15.9
WR150	6.050	120,000	144,000	2 1/2	1/2	1	6 1/4	4 7/16	2 3/4	1.66	2	15.5
WR150XHD	6.050	122,500	148,000	2 1/2	5/8	1	6 3/4	4 11/16	2 3/4	1.66	2	18
WR157	6.050	148,000	175,000	2 1/2	5/8	1 1/8	6 3/4	4 5/8	2 3/4	1.75	2	20

* WH denotes Heat Treated

** Interchangeable with 81X series, 88K series and C188 chain



WELDED STEEL DRAG CHAIN



Using select grade alloy steels these heavy duty chains are manufactured in North America to high standards. Our unique barrel forming process ensures consistent quality, reducing potential rivet wear and providing high strength and long service life. All heat treating and attachment options are available, as well as reverse barrel design.

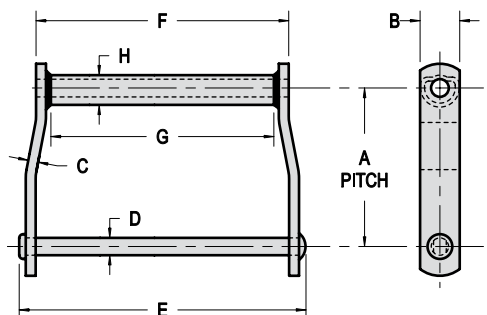

- Standard zone induction-hardened rivets for $\frac{3}{4}$ " and $\frac{7}{8}$ " diameters
- Standard through-hardened rivets for 1" diameters

All dimensions shown in inches unless noted otherwise

Chain Number	Average Pitch	Ultimate Strength (Pounds)	WH* Ultimate Strength (Pounds)	Sidebar Height	Sidebar Thickness	Rivet Diameter	Approx. Overall Width	Length of Bearing	Max. Sprocket Thickness	Barrel O.D.	Links per Foot	Average Weight per Foot (Pounds)
	A			B	C	D	E	F	G	H		
WD102	5.000	51,000	61,000	1 1/2	3/8	3/4	9 1/4	7 3/4	6 3/8	0.84	2.4	12
WD104	6.000	51,000	61,000	1 1/2	3/8	3/4	6 3/4	5 3/8	4 1/8	0.84	2	8.6
WD110	6.000	51,000	61,000	1 1/2	3/8	3/4	11 3/4	10 1/4	9	1.05	2	12
WD112	8.000	51,000	61,000	1 1/2	3/8	3/4	11 3/4	10 1/4	9	1.25	1.5	10
WD116	8.000	55,000	69,000	1 3/4	3/8	3/4	15 1/2	14 1/8	13	1.25	1.5	12.9
WD118	8.000	85,000	102,000	2	1/2	7/8 or 1	16 5/8	14 7/8	13 1/4	1.75	1.5	19.5
WD118XHD	8.000	125,000	150,000	2	5/8	1	16 5/8	14 7/8	13 1/4	1.75	1.5	22.75
WD120	6.000	70,000	90,000	2	1/2	7/8 or 1	12	10 1/4	8 1/2	1.25	2	19
WD120XHD	6.000	125,000	150,000	2	5/8	1	12	10 1/4	8 3/4	1.25	2	19
WD122	8.000	70,000	90,000	2	1/2	7/8 or 1	12	10 1/4	8 3/4	1.66	1.5	16
WD122XHD	8.000	125,000	150,000	2	5/8	1	12	10 1/4	8 3/4	1.66	1.5	16
WD480	8.000	70,000	90,000	2	1/2	7/8 or 1	14 1/2	12 3/4	11	1.66	1.5	17.2
WD480XHD	8.000	125,000	150,000	2	5/8	1	14 1/2	12 3/4	11	1.66	1.5	17.2

* WH denotes Heat Treated

The Two Strongest Reasons for Choosing Mac Welded Steel Chain.

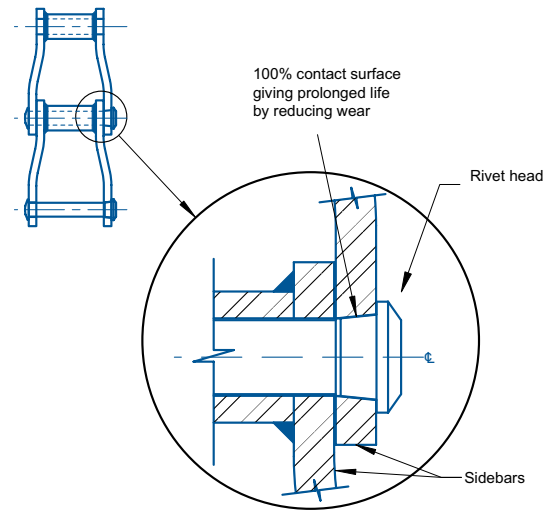

Induction-Hardened Rivets

Continual research and field testing has proven that the single most effective way to extend the life of large mill chain is by induction-hardening the chain rivets. The advantage of this process is that the rivet will have a super-tough surface on top of our through-hardened core. This hard surface offers superior wear resistance that greatly increases chain life and reduces costly downtime. We feel this process is so beneficial that it is included standard on all our welded steel mill chain with 1" and 1 1/8" rivets.

Precision Taper Fit Rivets

All Mac mill chain with a 1" and 1 1/8" rivet are constructed with Mac Precision Taper Fit rivets. These rivets are superior in design compared with conventional rivets. When the PTF rivet is pressed into the link, it provides 100% contact between the rivet and the sidebar, reducing wear and increasing chain life.

Consider upgrading with these options:

Pregreasing

Another excellent way to extend the life of welded steel chain is to choose factory pregreasing. Mac Chain can lubricate your chain rivets with a premium polymer grease that has high heat tolerance and is resistant to water washout. Pregreasing will significantly reduce initial break-in wear, increasing overall chain life by 25% or more.

Double-Locking

Rivets can be double-locked in place by welding the head and riveted end to the chain sidebars. This reduces possible rivet and sidebar hole wear that can lead to chain elongation in heavy load applications. Double-locked rivets also cannot become dangerous projectiles if sheared apart from severe impact loads.



Mac Chain Company Limited 9445 - 193A Street Surrey, BC V4N 4N5 Canada
www.macchain.com

Proudly distributed by:



www.dotmar.com.au • 1800 170 001 • sales@dotmar.com.au | www.dotmar.co.nz • 0800 650 750 • sales@dotmar.co.nz